

## Drawworks Specifications

The following table lists the specifications for the Commander™ Drawworks.

### Commander™ 1500 (Single Motor, 1.375" Cable)

|  |   |
|--|---|
| Nominal Power Rating                       |   |
| Continuous Duty:                           | 1500HP  |
| Drawworks Duty:                            | 1800 HP   |
| Motor:                                     | GEB 27 (1500 HP)  |
| Cable Drum Diameter (1st Layer):           | 30.0"   |
| Maximum Cable Diameter:                    | 1.375"  |
| Ratings at Layer Number:                   | 2   |
| Number of Layers (at Racking Boards):      | 3   |
| Number of Layers (Maximum, Under Crown):   | 5   |
| Maximum Single-Line Pull (Drawworks Duty): | 96,000 lbf  |
| Maximum Hook-Load:                         |   |
| 12 Lines                                   | 528,175 lbf   |
| 10 Lines                                   | 431,383 lbf   |
| 8 Lines                                    | 360,070 lbf   |
| Maximum Block Speed:                       |   |
| 12 Lines, 154,000 lbf load                 | 190 fpm   |
| 10 lines, 143,000 lbf load                 | 229 fpm   |
| 8 lines, 120,000 lbf load                  | 286 fpm   |
| Transmission Type:                         | Single Speed, Planetary Final Stage<br>1-Speed, Planetary Final Stage                       |
| Gear Type:                                 | Carburized/Ground; AGMA 11  |
| Transmission Ratio:                        | 8.51:1  |
| Lubrication:                               | Oil (includes Outboard Bearing), Electrically-driven Pump, Filter, Relief Valve, Oil Heater |
| Lubrication capacity:                      | 25 to 30 gallons  |
| Brake Types Available:                     | Johnson 68-HHH-OS Caliper Brake<br>Johnson 68-HHH-DNV Caliper Brake (optional)              |
| Brake Discs:                               | Two 49.0" disc  |
| Number of Calipers:                        | 3   |
| Dimensions (without skid)                  |   |
| Length:                                    | 118.00"   |
| Width:                                     | 125.00"   |
| Height:                                    | 72.00"  |
| Weight (with motors and skid):             | 34,000 lb   |
| Number of Catheads:                        | 2   |

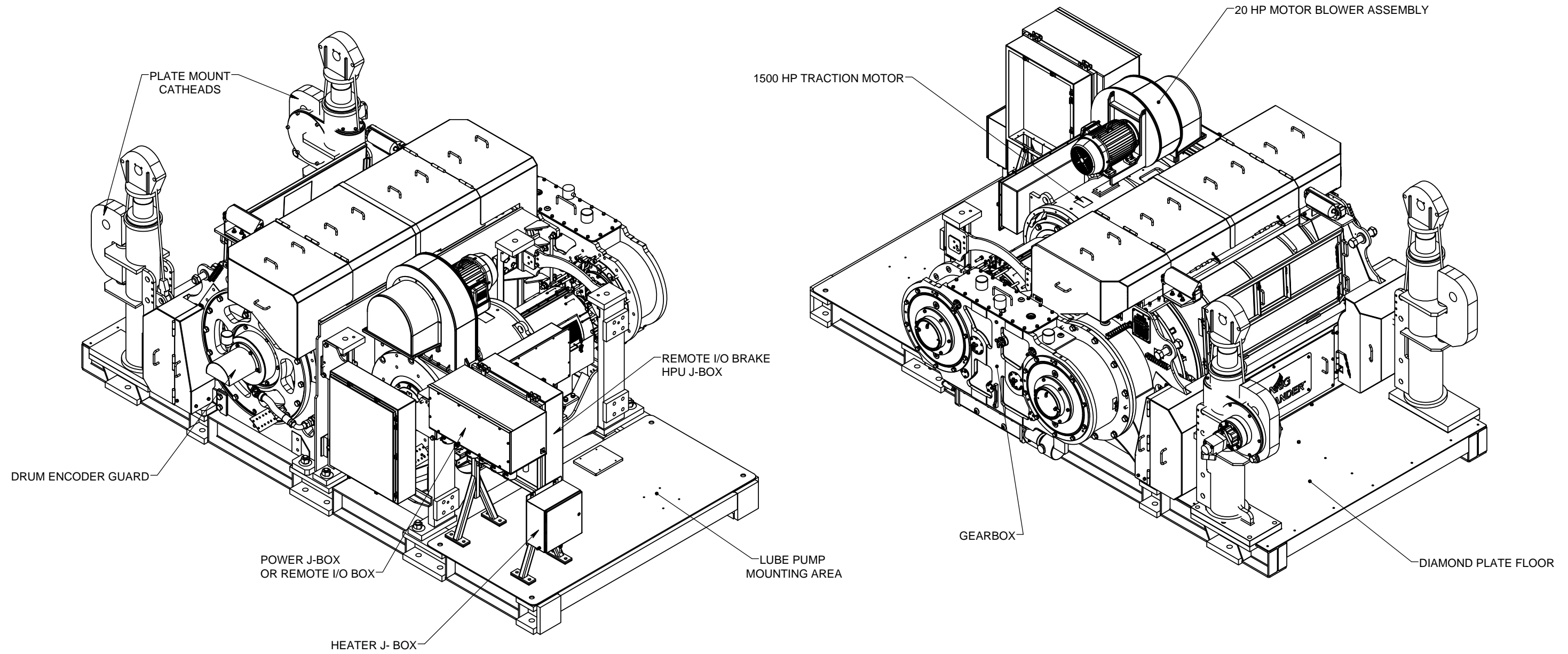

|  |  |  |  |  |   |  |  |   |            |
|--|--|--|--|--|---|--|--|---|------------|
| WELDING PROCEDURE AS PER CANRIG SPECIFICATION - ENG 704, UNLESS NOTED OTHERWISE  |  |  | INITIAL DESIGN<br>MODELED DJC 14/10/10<br>DRAWN F.LNAME<br>CHECKED F.LNAME<br>APPROVED F.LNAME<br>RELEASE DATE   |  | THIRD ANGLE PROJECTION<br>  |  |  |   |            |
| THIS DOCUMENT AND DESIGN ARE THE SOLE AND EXCLUSIVE PROPERTY OF CANRIG DRILLING TECHNOLOGY LTD. THIS DOCUMENT AND DESIGN SHALL NOT BE REPRODUCED, DISTRIBUTED OR OTHERWISE DISPOSED WITHOUT THE PRIOR WRITTEN AGREEMENT OF CANRIG AND SHALL BE RETURNED UPON DEMAND. ALL INTELLECTUAL PROPERTY RIGHTS ARE RESERVED.  |  |  | REVISION<br>MODELED -<br>DRAWN F.LNAME<br>CHECKED F.LNAME<br>APPROVED F.LNAME<br>REVISION RELEASE DATE   |  | DO NOT SCALE DRAWING<br>DRWKS, 2 MTR, STACKED, DISC BRAKES, 480V  |  |  | SHEET 1 OF 2<br>AY18972 GA ASSY<br>REV 01 |            |
| UNLESS OTHERWISE SPECIFIED<br>INTERPRET DRAWING PER ASME Y14.5-1994<br>INTERPRET CASTINGS AND FORGINGS PER ASME Y14.8-1996<br>REMOVE SHARP CORNERS AND BURRS<br>RUN OUT .003<br>STRAIGHTNESS ±.005 IN 5 INCHES<br>PERPENDICULARITY ±.010 IN 5 INCHES<br>PARALLELISM ±.010 IN 5 INCHES<br>FLATNESS ±.010 or as Shown<br>MACHINED SURFACES<br>MIN. RADIUS UNLESS SHOWN = 0.03 MAX. |  |  | TOLERANCE - UNLESS OTHERWISE SPECIFIED<br>FABRICATING [IMPERIAL] FABRICATING [METRIC]<br>0 to 24" ± 1/16" 0 TO 610 mm ± 1 mm<br>24" to 60" ± 1/8" 610 TO 1525 ± 3 mm<br>60 to 120" ± 3/16" 1525 TO 3048 ± 5 mm<br>120" to 280" ± 1/4" 3048 TO 7112 ± 7 mm<br>280" & OVER ± 1/2" 7112 & OVER ± 13 mm<br>MACHINING [IMPERIAL] MACHINING [METRIC]<br>DECIMAL .x ± .030" DECIMAL .x ± .8 mm<br>.xx ± .015" .xx ± .40 mm<br>.xxx ± .005" .xxx ± .13 mm<br>ANGULAR MACHINING ± 1° FABRICATION ± 2° |  | MATERIAL<br>EST. WEIGHT 43227.5 lbs<br>SCALE 1:16<br>SHEET SIZE D |  | REVISION<br>MODELED -<br>DRAWN F.LNAME<br>CHECKED F.LNAME<br>APPROVED F.LNAME<br>REVISION RELEASE DATE |   | REV [W] PJ |

| REV | REVISION DESCRIPTION | ECN |
|-----|----------------------|-----|
|     |                      |     |

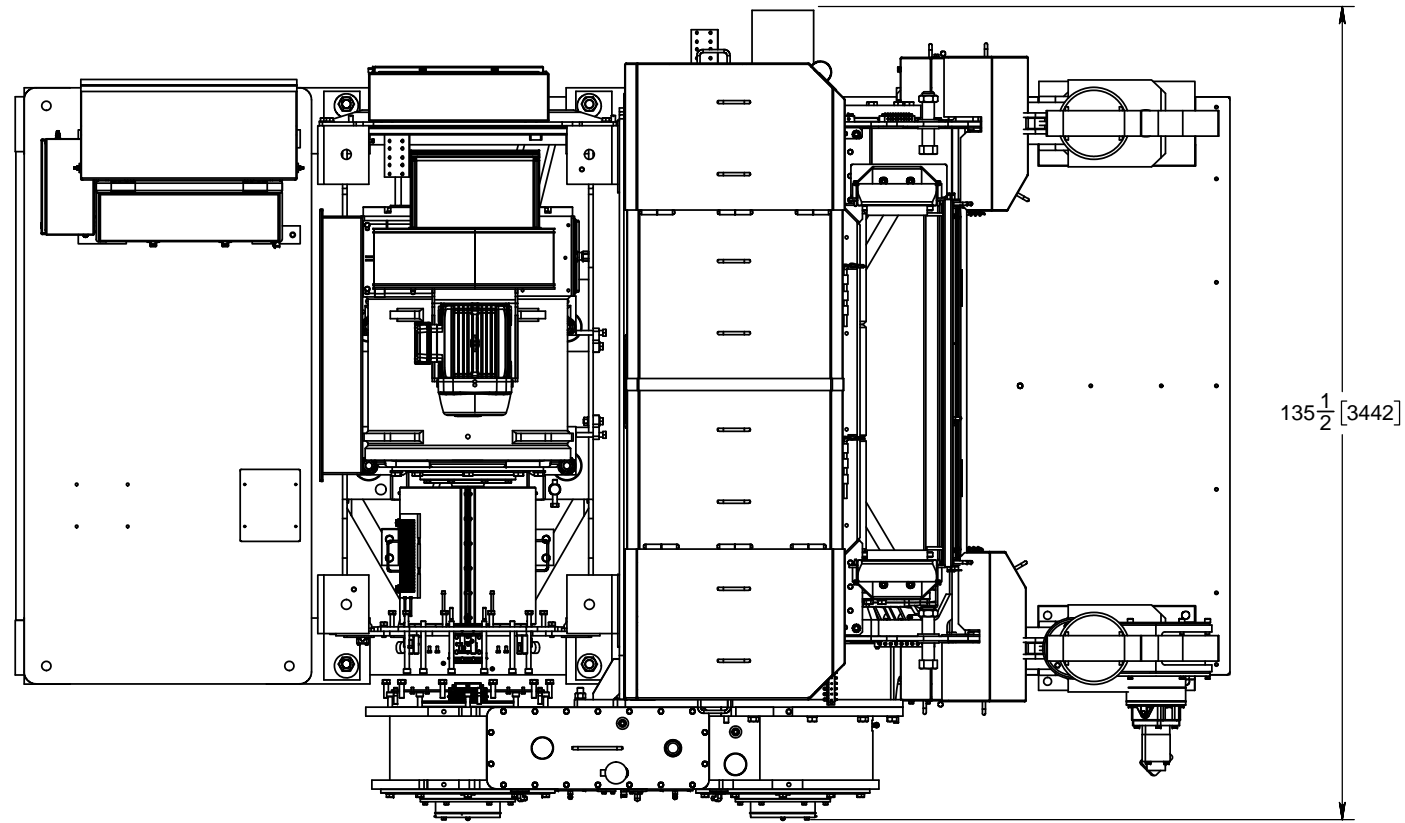

135  $\frac{1}{2}$  [3442]

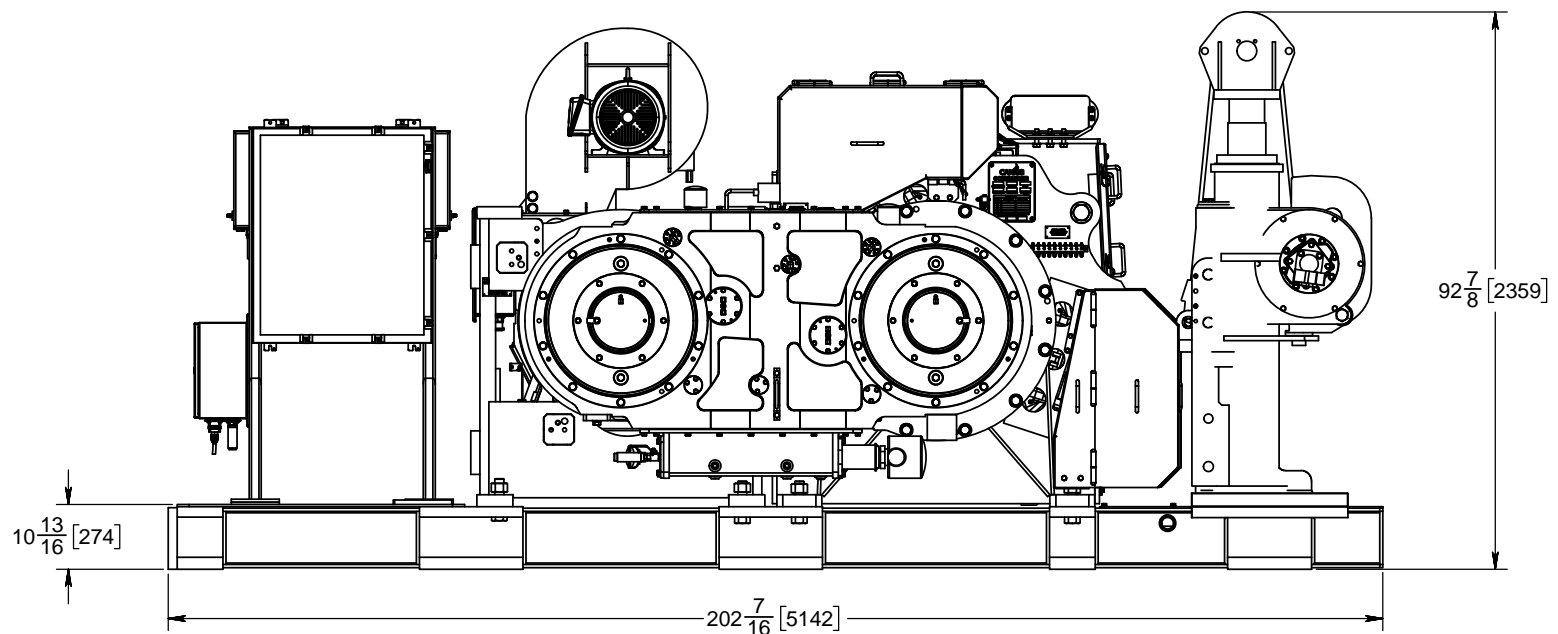

92  $\frac{7}{8}$  [2359]

10  $\frac{13}{16}$  [274]

202  $\frac{7}{16}$  [5142]

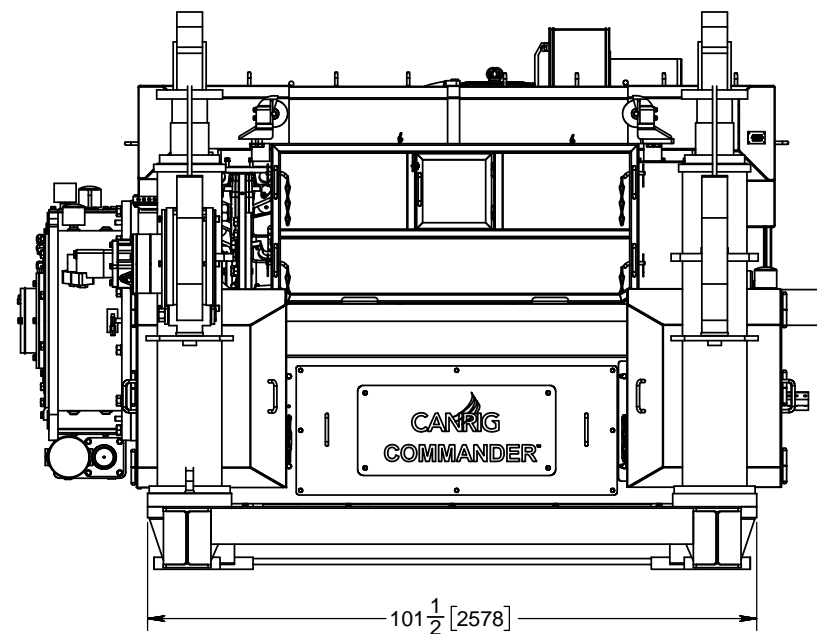

CANRIG  
COMMANDER

101  $\frac{1}{2}$  [2578]

UNLESS OTHERWISE SPECIFIED  
SEE SHEET 1 FOR DEFAULT  
TOLERANCES AND SPECIFICATIONS

THIS DOCUMENT AND DESIGN ARE THE  
SOLE AND EXCLUSIVE PROPERTY OF  
CANRIG DRILLING TECHNOLOGY LTD.  
THIS DOCUMENT AND DESIGN SHALL  
NOT BE REPRODUCED, DISTRIBUTED  
OR OTHERWISE DISPOSED WITHOUT  
THE PRIOR WRITTEN AGREEMENT OF  
CANRIG AND SHALL BE RETURNED  
UPON DEMAND. ALL INTELLECTUAL  
PROPERTY RIGHTS ARE RESERVED.

SCALE 1:16 SHEET SIZE D

THIRD ANGLE PROJECTION

DO NOT SCALE DRAWING

DRWKS, 2 MTR, STACKED, DISC BRAKES, 480V

SHEET 2 OF 2

AY18972 GA ASSY REV 01  
PJ

Hook-Load vs. Block-Speed, 12 Lines, LS Ratio = 8.51, HS Ratio = 8.51, Motor-Capacity Limited

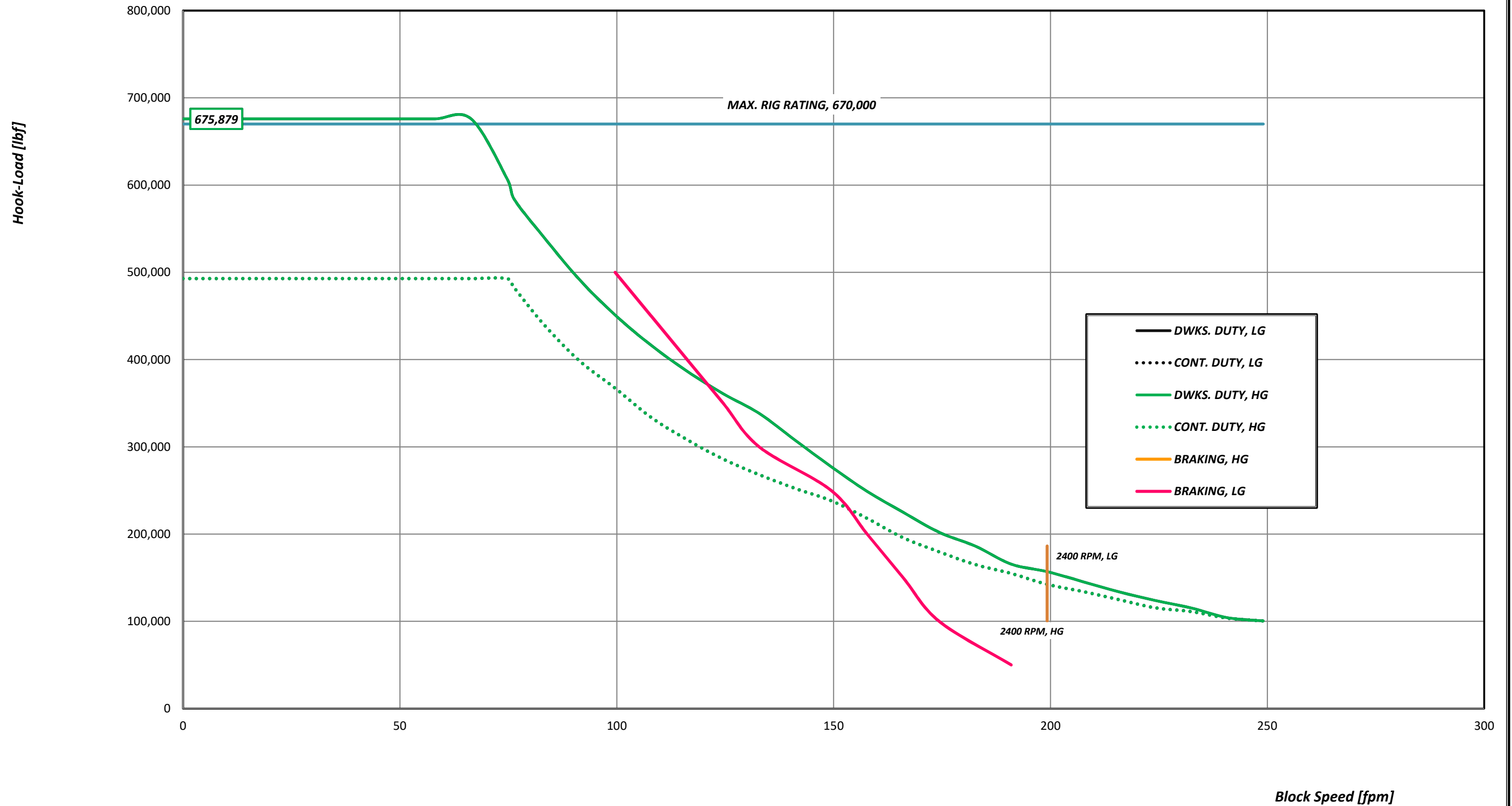

| Rig Rating | Motor Speed | Cont. Torque | Dwks. Torque | Cont. SLP in LG | Dwks. SLP in LG | Cont. SLP in MG | Dwks. SLP in MG | Cont. SLP in HG | Dwks. SLP in HG | Cont. Hook-Load in LG | Dwks. Hook-Load in LG | Block Speed in LG | 2400 RPM LG |  | 2400 RPM HG | Cont. Hook-Load in HG | Dwks. Hook-Load in HG | Block Speed in HG |
|------------|-------------|--------------|--------------|-----------------|-----------------|-----------------|-----------------|-----------------|-----------------|-----------------------|-----------------------|-------------------|-------------|--|-------------|-----------------------|-----------------------|-------------------|
| 670,000    | 0           | 8,750        | 12,000       | 52,981          | 72,660          | 0               | 0               | 52,981          | 72,660          | 492,828               | 675,879               | 0.00              | 199.24      |  | 199.24      | 492,828               | 675,879               | 0.00              |
| 670,000    | 100         | 8,750        | 12,000       | 52,981          | 72,660          | 0               | 0               | 52,981          | 72,660          | 492,828               | 675,879               | 8.30              | 199.24      |  | 199.24      | 492,828               | 675,879               | 8.30              |
| 670,000    | 200         | 8,750        | 12,000       | 52,981          | 72,660          | 0               | 0               | 52,981          | 72,660          | 492,828               | 675,879               | 16.60             | 199.24      |  | 199.24      | 492,828               | 675,879               | 16.60             |
| 670,000    | 300         | 8,750        | 12,000       | 52,981          | 72,660          | 0               | 0               | 52,981          | 72,660          | 492,828               | 675,879               | 24.90             | 199.24      |  | 199.24      | 492,828               | 675,879               | 24.90             |
| 670,000    | 400         | 8,750        | 12,000       | 52,981          | 72,660          | 0               | 0               | 52,981          | 72,660          | 492,828               | 675,879               | 33.21             | 199.24      |  | 199.24      | 492,828               | 675,879               | 33.21             |
| 670,000    | 500         | 8,750        | 12,000       | 52,981          | 72,660          | 0               | 0               | 52,981          | 72,660          | 492,828               | 675,879               | 41.51             | 199.24      |  | 199.24      | 492,828               | 675,879               | 41.51             |
| 670,000    | 600         | 8,750        | 12,000       | 52,981          | 72,660          | 0               | 0               | 52,981          | 72,660          | 492,828               | 675,879               | 49.81             | 199.24      |  | 199.24      | 492,828               | 675,879               | 49.81             |
| 670,000    | 700         | 8,750        | 12,000       | 52,981          | 72,660          | 0               | 0               | 52,981          | 72,660          | 492,828               | 675,879               | 58.11             | 199.24      |  | 199.24      | 492,828               | 675,879               | 58.11             |
| 670,000    | 800         | 8,750        | 12,000       | 52,981          | 72,660          | 0               | 0               | 52,981          | 72,660          | 492,828               | 675,879               | 66.41             | 199.24      |  | 199.24      | 492,828               | 675,879               | 66.41             |
| 670,000    | 900         | 8,750        | 10,780       | 52,981          | 65,273          | 0               | 0               | 52,981          | 65,273          | 492,828               | 607,165               | 74.71             | 199.24      |  | 199.24      | 492,828               | 607,165               | 74.71             |
| 670,000    | 920         | 8,561        | 10,360       | 51,837          | 62,730          | 0               | 0               | 51,837          | 62,730          | 482,183               | 583,509               | 76.37             | 199.24      |  | 199.24      | 482,183               | 583,509               | 76.37             |
| 670,000    | 1,000       | 7,834        | 9,611        | 47,435          | 58,196          | 0               | 0               | 47,435          | 58,196          | 441,236               | 541,332               | 83.01             | 199.24      |  | 199.24      | 441,236               | 541,332               | 83.01             |
| 670,000    | 1,100       | 7,082        | 8,737        | 42,882          | 52,903          | 0               | 0               | 42,882          | 52,903          | 398,881               | 492,096               | 91.32             | 199.24      |  | 199.24      | 398,881               | 492,096               | 91.32             |
| 670,000    | 1,200       | 6,520        | 8,009        | 39,479          | 48,496          | 0               | 0               | 39,479          | 48,496          | 367,228               | 451,110               | 99.62             | 199.24      |  | 199.24      | 367,228               | 451,110               | 99.62             |
| 670,000    | 1,300       | 5,925        | 7,393        | 35,876          | 44,766          | 0               | 0               | 35,876          | 44,766          | 333,715               | 416,409               | 107.92            | 199.24      |  | 199.24      | 333,715               | 416,409               | 107.92            |
| 670,000    | 1,400       | 5,471        | 6,865        | 33,127          | 41,568          | 0               | 0               | 33,127          | 41,568          | 308,144               | 386,665               | 116.22            | 199.24      |  | 199.24      | 308,144               | 386,665               | 116.22            |
| 670,000    | 1,500       | 5,077        | 6,407        | 30,741          | 38,797          | 0               | 0               | 30,741          | 38,797          | 285,953               | 360,886               | 124.52            | 199.24      |  | 199.24      | 285,953               | 360,886               | 124.52            |
| 670,000    | 1,600       | 4,760        | 6,007        | 28,822          | 36,372          | 0               | 0               | 28,822          | 36,372          | 268,099               | 338,334               | 132.82            | 199.24      |  | 199.24      | 268,099               | 338,334               | 132.82            |
| 670,000    | 1,700       | 4,480        | 5,461        | 27,126          | 33,066          | 0               | 0               | 27,126          | 33,066          | 252,328               | 307,581               | 141.13            | 199.24      |  | 199.24      | 252,328               | 307,581               | 141.13            |
| 670,000    | 1,800       | 4,230        | 4,923        | 25,613          | 29,809          | 0               | 0               | 25,613          | 29,809          | 238,247               | 277,279               | 149.43            | 199.24      |  | 199.24      | 238,247               | 277,279               | 149.43            |
| 670,000    | 1,900       | 3,870        | 4,420        | 23,433          | 26,763          | 0               | 0               | 23,433          | 26,763          | 217,971               | 248,949               | 157.73            | 199.24      |  | 199.24      | 217,971               | 248,949               | 157.73            |
| 670,000    | 2,000       | 3,476        | 3,995        | 21,047          | 24,190          | 0               | 0               | 21,047          | 24,190          | 195,780               | 225,011               | 166.03            | 199.24      |  | 199.24      | 195,780               | 225,011               | 166.03            |
| 670,000    | 2,100       | 3,190        | 3,586        | 19,315          | 21,713          | 0               | 0               | 19,315          | 21,713          | 179,671               | 201,975               | 174.33            | 199.24      |  | 199.24      | 179,671               | 201,975               | 174.33            |
| 670,000    | 2,200       | 2,931        | 3,307        | 17,747          | 20,024          | 0               | 0               | 17,747          | 20,024          | 165,083               | 186,261               | 182.63            | 199.24      |  | 199.24      | 165,083               | 186,261               | 182.63            |
| 670,000    | 2,300       | 2,750        | 2,940        | 16,651          | 17,802          | 0               | 0               | 16,651          | 17,802          | 154,889               | 165,590               | 190.93            | 199.24      |  | 199.24      | 154,889               | 165,590               | 190.93            |
| 670,000    | 2,400       | 2,528        | 2,786        | 15,307          | 16,869          | 0               | 0               | 15,307          | 16,869          | 142,385               | 156,917               | 199.24            | 199.24      |  | 199.24      | 142,385               | 156,917               | 199.24            |
| 670,000    | 2,500       | 2,380        | 2,580        | 14,411          | 15,622          | 0               | 0               | 14,411          | 15,622          | 134,049               | 145,314               | 207.54            | 199.24      |  | 199.24      | 134,049               | 145,314               | 207.54            |
| 670,000    | 2,600       | 2,216        | 2,374        | 13,418          | 14,375          | 0               | 0               | 13,418          | 14,375          | 124,812               | 133,711               | 215.84            | 199.24      |  | 199.24      | 124,812               | 133,711               | 215.84            |
| 670,000    | 2,700       | 2,050        | 2,200        | 12,413          | 13,321          | 0               | 0               | 12,413          | 13,321          | 115,463               | 123,911               | 224.14            | 199.24      |  | 199.24      | 115,463               | 123,911               | 224.14            |
| 670,000    | 2,800       | 1,974        | 2,047        | 11,953          | 12,395          | 0               | 0               | 11,953          | 12,395          | 111,182               | 115,294               | 232.44            | 199.24      |  | 199.24      | 111,182               | 115,294               | 232.44            |
| 670,000    | 2,900       | 1,840        | 1,850        | 11,141          | 11,202          | 0               | 0               | 11,141          | 11,202          | 103,635               | 104,198               | 240.74            | 199.24      |  | 199.24      | 103,635               | 104,198               | 240.74            |
| 670,000    | 3,000       | 1,783        | 1,783        | 10,796          | 10,796          | 0               | 0               | 10,796          | 10,796          | 100,424               | 100,424               | 249.04            | 199.24      |  | 199.24      | 100,424               | 100,424               | 249.04            |

Hook-Load vs. Block  
96,000 Motor-Capacity Limited

Hook-Load vs. Block-Speed, 10 Lines, LS Ratio = 8.51, HS Ratio = 8.51, Motor-Capacity Limited

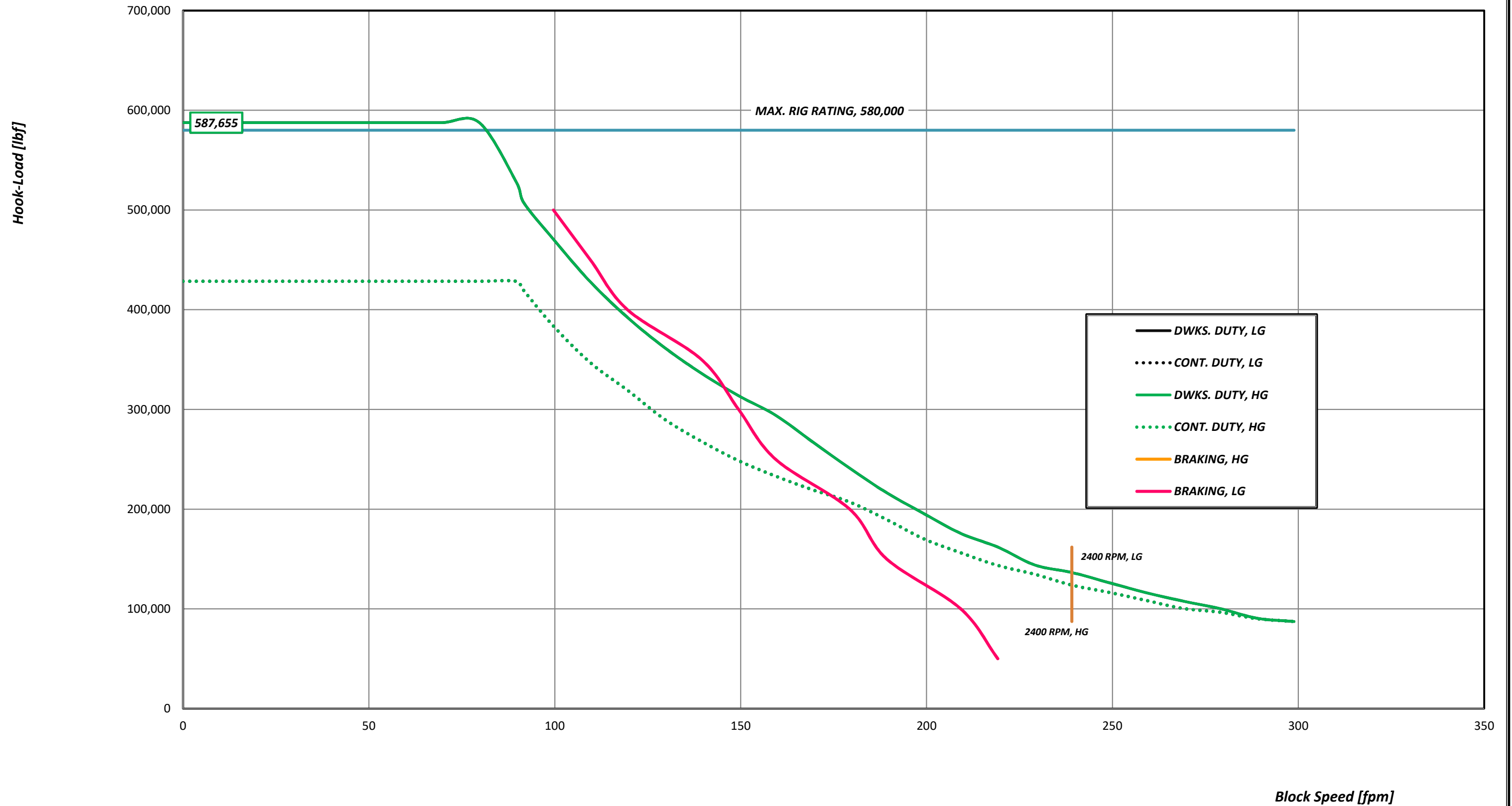

| Rig Rating | Motor Speed | Cont. Torque | Dwks. Torque | Cont. SLP in LG | Dwks. SLP in LG | Cont. SLP in MG | Dwks. SLP in MG | Cont. SLP in HG | Dwks. SLP in HG | Cont. Hook-Load in LG | Dwks. Hook-Load in LG | Block Speed in LG | 2400 RPM LG | 2400 RPM HG | Cont. Hook-Load in HG | Dwks. Hook-Load in HG | Block Speed in HG |
|------------|-------------|--------------|--------------|-----------------|-----------------|-----------------|-----------------|-----------------|-----------------|-----------------------|-----------------------|-------------------|-------------|-------------|-----------------------|-----------------------|-------------------|
| 580,000    | 0           | 8,750        | 12,000       | 52,981          | 72,660          | 0               | 0               | 52,981          | 72,660          | 428,498               | 587,655               | 0.00              | 239.08      | 239.08      | 428,498               | 587,655               | 0.00              |
| 580,000    | 100         | 8,750        | 12,000       | 52,981          | 72,660          | 0               | 0               | 52,981          | 72,660          | 428,498               | 587,655               | 9.96              | 239.08      | 239.08      | 428,498               | 587,655               | 9.96              |
| 580,000    | 200         | 8,750        | 12,000       | 52,981          | 72,660          | 0               | 0               | 52,981          | 72,660          | 428,498               | 587,655               | 19.92             | 239.08      | 239.08      | 428,498               | 587,655               | 19.92             |
| 580,000    | 300         | 8,750        | 12,000       | 52,981          | 72,660          | 0               | 0               | 52,981          | 72,660          | 428,498               | 587,655               | 29.89             | 239.08      | 239.08      | 428,498               | 587,655               | 29.89             |
| 580,000    | 400         | 8,750        | 12,000       | 52,981          | 72,660          | 0               | 0               | 52,981          | 72,660          | 428,498               | 587,655               | 39.85             | 239.08      | 239.08      | 428,498               | 587,655               | 39.85             |
| 580,000    | 500         | 8,750        | 12,000       | 52,981          | 72,660          | 0               | 0               | 52,981          | 72,660          | 428,498               | 587,655               | 49.81             | 239.08      | 239.08      | 428,498               | 587,655               | 49.81             |
| 580,000    | 600         | 8,750        | 12,000       | 52,981          | 72,660          | 0               | 0               | 52,981          | 72,660          | 428,498               | 587,655               | 59.77             | 239.08      | 239.08      | 428,498               | 587,655               | 59.77             |
| 580,000    | 700         | 8,750        | 12,000       | 52,981          | 72,660          | 0               | 0               | 52,981          | 72,660          | 428,498               | 587,655               | 69.73             | 239.08      | 239.08      | 428,498               | 587,655               | 69.73             |
| 580,000    | 800         | 8,750        | 12,000       | 52,981          | 72,660          | 0               | 0               | 52,981          | 72,660          | 428,498               | 587,655               | 79.69             | 239.08      | 239.08      | 428,498               | 587,655               | 79.69             |
| 580,000    | 900         | 8,750        | 10,780       | 52,981          | 65,273          | 0               | 0               | 52,981          | 65,273          | 428,498               | 527,910               | 89.66             | 239.08      | 239.08      | 428,498               | 527,910               | 89.66             |
| 580,000    | 920         | 8,561        | 10,360       | 51,837          | 62,730          | 0               | 0               | 51,837          | 62,730          | 419,243               | 507,342               | 91.65             | 239.08      | 239.08      | 419,243               | 507,342               | 91.65             |
| 580,000    | 1,000       | 7,834        | 9,611        | 47,435          | 58,196          | 0               | 0               | 47,435          | 58,196          | 383,641               | 470,670               | 99.62             | 239.08      | 239.08      | 383,641               | 470,670               | 99.62             |
| 580,000    | 1,100       | 7,082        | 8,737        | 42,882          | 52,903          | 0               | 0               | 42,882          | 52,903          | 346,814               | 427,862               | 109.58            | 239.08      | 239.08      | 346,814               | 427,862               | 109.58            |
| 580,000    | 1,200       | 6,520        | 8,009        | 39,479          | 48,496          | 0               | 0               | 39,479          | 48,496          | 319,292               | 392,225               | 119.54            | 239.08      | 239.08      | 319,292               | 392,225               | 119.54            |
| 580,000    | 1,300       | 5,925        | 7,393        | 35,876          | 44,766          | 0               | 0               | 35,876          | 44,766          | 290,155               | 362,054               | 129.50            | 239.08      | 239.08      | 290,155               | 362,054               | 129.50            |
| 580,000    | 1,400       | 5,471        | 6,865        | 33,127          | 41,568          | 0               | 0               | 33,127          | 41,568          | 267,922               | 336,192               | 139.46            | 239.08      | 239.08      | 267,922               | 336,192               | 139.46            |
| 580,000    | 1,500       | 5,077        | 6,407        | 30,741          | 38,797          | 0               | 0               | 30,741          | 38,797          | 248,627               | 313,778               | 149.43            | 239.08      | 239.08      | 248,627               | 313,778               | 149.43            |
| 580,000    | 1,600       | 4,760        | 6,007        | 28,822          | 36,372          | 0               | 0               | 28,822          | 36,372          | 233,103               | 294,170               | 159.39            | 239.08      | 239.08      | 233,103               | 294,170               | 159.39            |
| 580,000    | 1,700       | 4,480        | 5,461        | 27,126          | 33,066          | 0               | 0               | 27,126          | 33,066          | 219,391               | 267,432               | 169.35            | 239.08      | 239.08      | 219,391               | 267,432               | 169.35            |
| 580,000    | 1,800       | 4,230        | 4,923        | 25,613          | 29,809          | 0               | 0               | 25,613          | 29,809          | 207,148               | 241,085               | 179.31            | 239.08      | 239.08      | 207,148               | 241,085               | 179.31            |
| 580,000    | 1,900       | 3,870        | 4,420        | 23,433          | 26,763          | 0               | 0               | 23,433          | 26,763          | 189,519               | 216,453               | 189.27            | 239.08      | 239.08      | 189,519               | 216,453               | 189.27            |
| 580,000    | 2,000       | 3,476        | 3,995        | 21,047          | 24,190          | 0               | 0               | 21,047          | 24,190          | 170,224               | 195,640               | 199.24            | 239.08      | 239.08      | 170,224               | 195,640               | 199.24            |
| 580,000    | 2,100       | 3,190        | 3,586        | 19,315          | 21,713          | 0               | 0               | 19,315          | 21,713          | 156,218               | 175,611               | 209.20            | 239.08      | 239.08      | 156,218               | 175,611               | 209.20            |
| 580,000    | 2,200       | 2,931        | 3,307        | 17,747          | 20,024          | 0               | 0               | 17,747          | 20,024          | 143,535               | 161,948               | 219.16            | 239.08      | 239.08      | 143,535               | 161,948               | 219.16            |
| 580,000    | 2,300       | 2,750        | 2,940        | 16,651          | 17,802          | 0               | 0               | 16,651          | 17,802          | 134,671               | 143,975               | 229.12            | 239.08      | 239.08      | 134,671               | 143,975               | 229.12            |
| 580,000    | 2,400       | 2,528        | 2,786        | 15,307          | 16,869          | 0               | 0               | 15,307          | 16,869          | 123,799               | 136,434               | 239.08            | 239.08      | 239.08      | 123,799               | 136,434               | 239.08            |
| 580,000    | 2,500       | 2,380        | 2,580        | 14,411          | 15,622          | 0               | 0               | 14,411          | 15,622          | 116,552               | 126,346               | 249.04            | 239.08      | 239.08      | 116,552               | 126,346               | 249.04            |
| 580,000    | 2,600       | 2,216        | 2,374        | 13,418          | 14,375          | 0               | 0               | 13,418          | 14,375          | 108,520               | 116,258               | 259.01            | 239.08      | 239.08      | 108,520               | 116,258               | 259.01            |
| 580,000    | 2,700       | 2,050        | 2,200        | 12,413          | 13,321          | 0               | 0               | 12,413          | 13,321          | 100,391               | 107,737               | 268.97            | 239.08      | 239.08      | 100,391               | 107,737               | 268.97            |
| 580,000    | 2,800       | 1,974        | 2,047        | 11,953          | 12,395          | 0               | 0               | 11,953          | 12,395          | 96,669                | 100,244               | 278.93            | 239.08      | 239.08      | 96,669                | 100,244               | 278.93            |
| 580,000    | 2,900       | 1,840        | 1,850        | 11,141          | 11,202          | 0               | 0               | 11,141          | 11,202          | 90,107                | 90,597                | 288.89            | 239.08      | 239.08      | 90,107                | 90,597                | 288.89            |
| 580,000    | 3,000       | 1,783        | 1,783        | 10,796          | 10,796          | 0               | 0               | 10,796          | 10,796          | 87,316                | 87,316                | 298.85            | 239.08      | 239.08      | 87,316                | 87,316                | 298.85            |

Hook-Load vs. Block  
96,000 Motor-Capacity Limited

Hook-Load vs. Block-Speed, 8 Lines, LS Ratio = 8.51, HS Ratio = 8.51, Motor-Capacity Limited

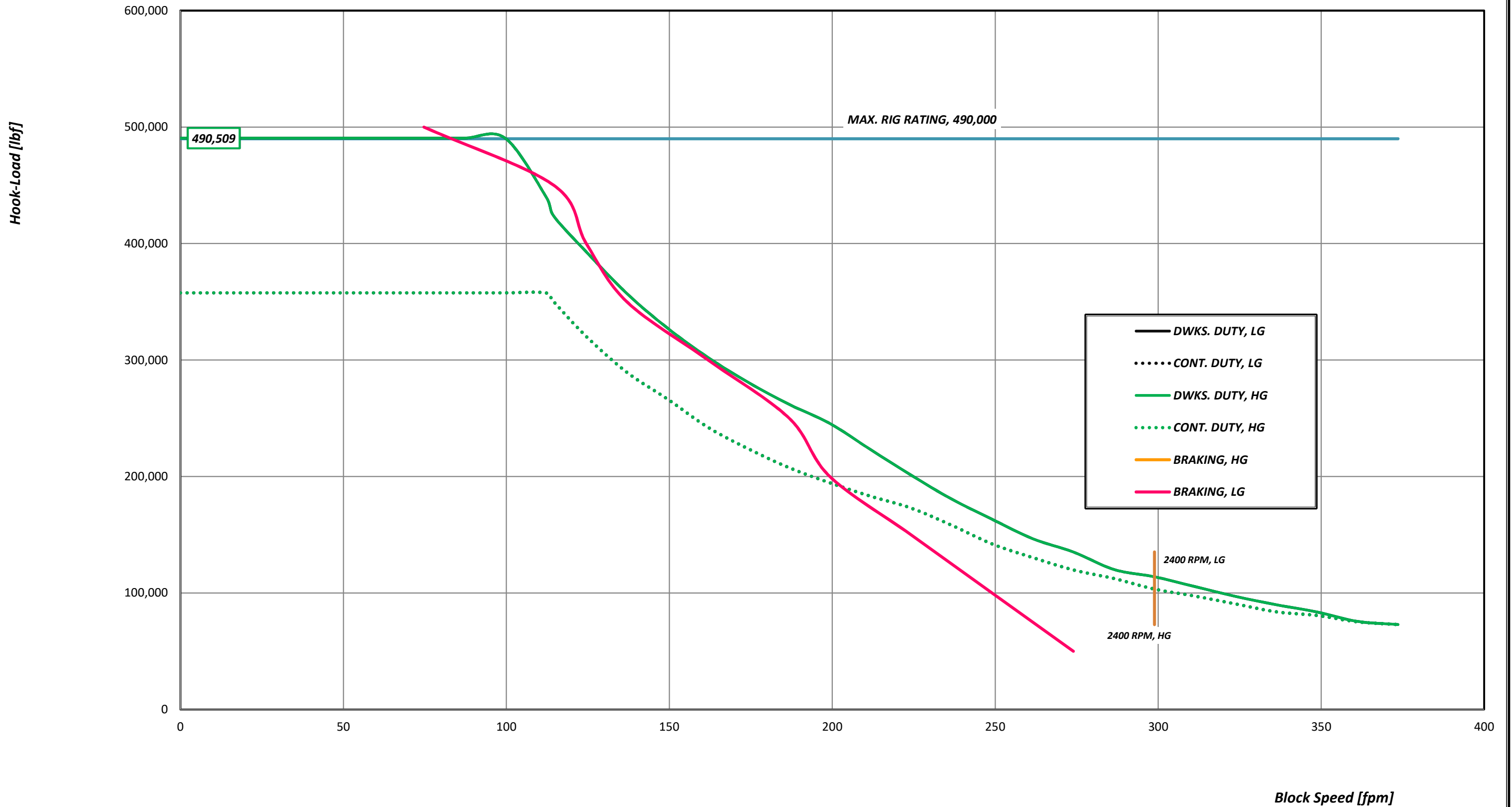



| Rig Rating | Motor Speed | Cont. Torque | Dwks. Torque | Cont. SLP in LG | Dwks. SLP in LG | Cont. SLP in MG | Dwks. SLP in MG | Cont. SLP in HG | Dwks. SLP in HG | Cont. Hook-Load in LG | Dwks. Hook-Load in LG | Block Speed in LG | 2400 RPM LG | 2400 RPM HG | Cont. Hook-Load in HG | Dwks. Hook-Load in HG | Block Speed in HG |
|------------|-------------|--------------|--------------|-----------------|-----------------|-----------------|-----------------|-----------------|-----------------|-----------------------|-----------------------|-------------------|-------------|-------------|-----------------------|-----------------------|-------------------|
| 490,000    | 0           | 8,750        | 12,000       | 52,981          | 72,660          | 0               | 0               | 52,981          | 72,660          | 357,663               | 490,509               | 0.00              | 298.85      | 298.85      | 357,663               | 490,509               | 0.00              |
| 490,000    | 100         | 8,750        | 12,000       | 52,981          | 72,660          | 0               | 0               | 52,981          | 72,660          | 357,663               | 490,509               | 12.45             | 298.85      | 298.85      | 357,663               | 490,509               | 12.45             |
| 490,000    | 200         | 8,750        | 12,000       | 52,981          | 72,660          | 0               | 0               | 52,981          | 72,660          | 357,663               | 490,509               | 24.90             | 298.85      | 298.85      | 357,663               | 490,509               | 24.90             |
| 490,000    | 300         | 8,750        | 12,000       | 52,981          | 72,660          | 0               | 0               | 52,981          | 72,660          | 357,663               | 490,509               | 37.36             | 298.85      | 298.85      | 357,663               | 490,509               | 37.36             |
| 490,000    | 400         | 8,750        | 12,000       | 52,981          | 72,660          | 0               | 0               | 52,981          | 72,660          | 357,663               | 490,509               | 49.81             | 298.85      | 298.85      | 357,663               | 490,509               | 49.81             |
| 490,000    | 500         | 8,750        | 12,000       | 52,981          | 72,660          | 0               | 0               | 52,981          | 72,660          | 357,663               | 490,509               | 62.26             | 298.85      | 298.85      | 357,663               | 490,509               | 62.26             |
| 490,000    | 600         | 8,750        | 12,000       | 52,981          | 72,660          | 0               | 0               | 52,981          | 72,660          | 357,663               | 490,509               | 74.71             | 298.85      | 298.85      | 357,663               | 490,509               | 74.71             |
| 490,000    | 700         | 8,750        | 12,000       | 52,981          | 72,660          | 0               | 0               | 52,981          | 72,660          | 357,663               | 490,509               | 87.17             | 298.85      | 298.85      | 357,663               | 490,509               | 87.17             |
| 490,000    | 800         | 8,750        | 12,000       | 52,981          | 72,660          | 0               | 0               | 52,981          | 72,660          | 357,663               | 490,509               | 99.62             | 298.85      | 298.85      | 357,663               | 490,509               | 99.62             |
| 490,000    | 900         | 8,750        | 10,780       | 52,981          | 65,273          | 0               | 0               | 52,981          | 65,273          | 357,663               | 440,641               | 112.07            | 298.85      | 298.85      | 357,663               | 440,641               | 112.07            |
| 490,000    | 920         | 8,561        | 10,360       | 51,837          | 62,730          | 0               | 0               | 51,837          | 62,730          | 349,937               | 423,473               | 114.56            | 298.85      | 298.85      | 349,937               | 423,473               | 114.56            |
| 490,000    | 1,000       | 7,834        | 9,611        | 47,435          | 58,196          | 0               | 0               | 47,435          | 58,196          | 320,221               | 392,863               | 124.52            | 298.85      | 298.85      | 320,221               | 392,863               | 124.52            |
| 490,000    | 1,100       | 7,082        | 8,737        | 42,882          | 52,903          | 0               | 0               | 42,882          | 52,903          | 289,482               | 357,131               | 136.97            | 298.85      | 298.85      | 289,482               | 357,131               | 136.97            |
| 490,000    | 1,200       | 6,520        | 8,009        | 39,479          | 48,496          | 0               | 0               | 39,479          | 48,496          | 266,510               | 327,386               | 149.43            | 298.85      | 298.85      | 266,510               | 327,386               | 149.43            |
| 490,000    | 1,300       | 5,925        | 7,393        | 35,876          | 44,766          | 0               | 0               | 35,876          | 44,766          | 242,189               | 302,203               | 161.88            | 298.85      | 298.85      | 242,189               | 302,203               | 161.88            |
| 490,000    | 1,400       | 5,471        | 6,865        | 33,127          | 41,568          | 0               | 0               | 33,127          | 41,568          | 223,631               | 280,616               | 174.33            | 298.85      | 298.85      | 223,631               | 280,616               | 174.33            |
| 490,000    | 1,500       | 5,077        | 6,407        | 30,741          | 38,797          | 0               | 0               | 30,741          | 38,797          | 207,526               | 261,907               | 186.78            | 298.85      | 298.85      | 207,526               | 261,907               | 186.78            |
| 490,000    | 1,600       | 4,760        | 6,007        | 28,822          | 36,372          | 0               | 0               | 28,822          | 36,372          | 194,569               | 245,541               | 199.24            | 298.85      | 298.85      | 194,569               | 245,541               | 199.24            |
| 490,000    | 1,700       | 4,480        | 5,461        | 27,126          | 33,066          | 0               | 0               | 27,126          | 33,066          | 183,123               | 223,222               | 211.69            | 298.85      | 298.85      | 183,123               | 223,222               | 211.69            |
| 490,000    | 1,800       | 4,230        | 4,923        | 25,613          | 29,809          | 0               | 0               | 25,613          | 29,809          | 172,904               | 201,231               | 224.14            | 298.85      | 298.85      | 172,904               | 201,231               | 224.14            |
| 490,000    | 1,900       | 3,870        | 4,420        | 23,433          | 26,763          | 0               | 0               | 23,433          | 26,763          | 158,189               | 180,671               | 236.59            | 298.85      | 298.85      | 158,189               | 180,671               | 236.59            |
| 490,000    | 2,000       | 3,476        | 3,995        | 21,047          | 24,190          | 0               | 0               | 21,047          | 24,190          | 142,084               | 163,299               | 249.04            | 298.85      | 298.85      | 142,084               | 163,299               | 249.04            |
| 490,000    | 2,100       | 3,190        | 3,586        | 19,315          | 21,713          | 0               | 0               | 19,315          | 21,713          | 130,394               | 146,580               | 261.50            | 298.85      | 298.85      | 130,394               | 146,580               | 261.50            |
| 490,000    | 2,200       | 2,931        | 3,307        | 17,747          | 20,024          | 0               | 0               | 17,747          | 20,024          | 119,807               | 135,176               | 273.95            | 298.85      | 298.85      | 119,807               | 135,176               | 273.95            |
| 490,000    | 2,300       | 2,750        | 2,940        | 16,651          | 17,802          | 0               | 0               | 16,651          | 17,802          | 112,408               | 120,175               | 286.40            | 298.85      | 298.85      | 112,408               | 120,175               | 286.40            |
| 490,000    | 2,400       | 2,528        | 2,786        | 15,307          | 16,869          | 0               | 0               | 15,307          | 16,869          | 103,334               | 113,880               | 298.85            | 298.85      | 298.85      | 103,334               | 113,880               | 298.85            |
| 490,000    | 2,500       | 2,380        | 2,580        | 14,411          | 15,622          | 0               | 0               | 14,411          | 15,622          | 97,284                | 105,459               | 311.31            | 298.85      | 298.85      | 97,284                | 105,459               | 311.31            |
| 490,000    | 2,600       | 2,216        | 2,374        | 13,418          | 14,375          | 0               | 0               | 13,418          | 14,375          | 90,581                | 97,039                | 323.76            | 298.85      | 298.85      | 90,581                | 97,039                | 323.76            |
| 490,000    | 2,700       | 2,050        | 2,200        | 12,413          | 13,321          | 0               | 0               | 12,413          | 13,321          | 83,795                | 89,927                | 336.21            | 298.85      | 298.85      | 83,795                | 89,927                | 336.21            |
| 490,000    | 2,800       | 1,974        | 2,047        | 11,953          | 12,395          | 0               | 0               | 11,953          | 12,395          | 80,689                | 83,673                | 348.66            | 298.85      | 298.85      | 80,689                | 83,673                | 348.66            |
| 490,000    | 2,900       | 1,840        | 1,850        | 11,141          | 11,202          | 0               | 0               | 11,141          | 11,202          | 75,211                | 75,620                | 361.11            | 298.85      | 298.85      | 75,211                | 75,620                | 361.11            |
| 490,000    | 3,000       | 1,783        | 1,783        | 10,796          | 10,796          | 0               | 0               | 10,796          | 10,796          | 72,881                | 72,881                | 373.57            | 298.85      | 298.85      | 72,881                | 72,881                | 373.57            |

Hook-Load vs. Block 8  
96,000 Motor-Capacity Limited